

<b>Seitenwand</b>	<b>DE</b>	Montage- und Gebrauchsanleitung
<b>Side panel</b>	<b>EN</b>	Installation and usage instructions
<b>Fermeture laterale</b>	<b>FR</b>	Instructions de montage et mode d'emploi
<b>Cierre lateral</b>	<b>ES</b>	Instrucciones de montaje y uso
<b>Parete laterale</b>	<b>IT</b>	Istruzioni di montaggio e d'uso

## SUN VIEW SIDE SUN VIEW SIDE XL

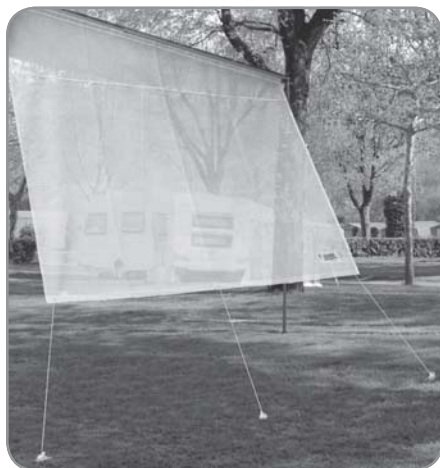

**CARAVANSTORE / F35**

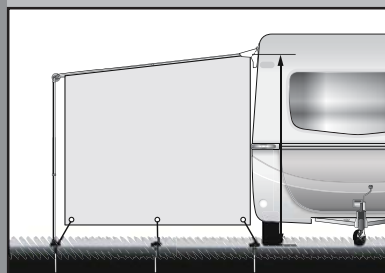

Made in Italy

**Fiammastore**

**DE** Produktanleitung für  
**FR** Instructions de produit pour  
**IT** Istruzioni prodotto per

**EN** Product instructions for  
**ES** Instruccion producto para

Code	Description
97961-07-	SUN VIEW SIDE CARAVANSTORE/F35
97961-008	SUN VIEW SIDE CARAVANSTORE XL

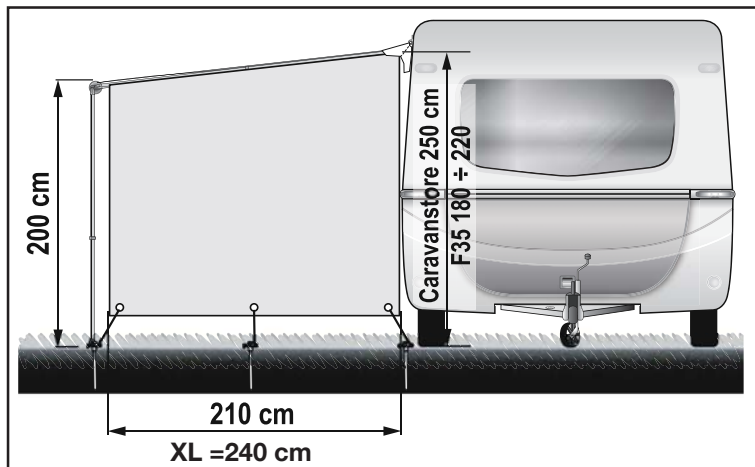

**DE** Kontrolle bei der Übernahme  
**FR** Contrôle à la réception  
**IT** Controllo al ricevimento

**EN** Goods receipt inspection  
**ES** Control al recibimiento

**DE** Bitte kontrollieren Sie, dass alle Einzelteile einwandfrei sind und nicht während dem Transport beschädigt wurden. Wenden Sie sich in diesem Falle an Ihren Händler.

**EN** Check that nothing has been damaged or deformed during transport.  
In case of damage please contact the dealer.

**FR** Contrôler qu'aucune pièce ne soit cassée ou déformée suite au transport.  
En cas contraire, contacter le revendeur.

**ES** Controlar que ningún detalle se haya roto o deformado durante el transporte.  
En este caso contactar al revendedor.

**IT** Controllare che nessun particolare sia rotto o deformato a causa di errori di trasporto. In questo caso contattare il rivenditore.

**DE** Verpackungsinhalt  
**FR** Contenu de l'emballage  
**IT** Contenuto dell'imballo

**EN** Package contents  
**ES** Contenido del embalaje

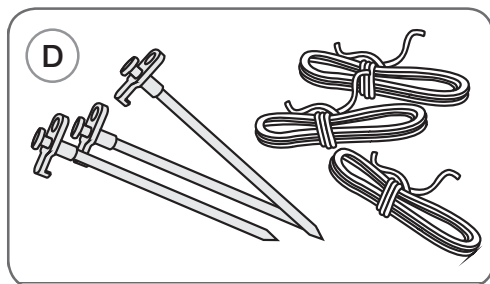
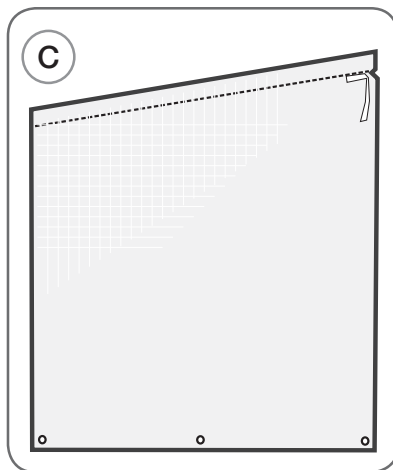
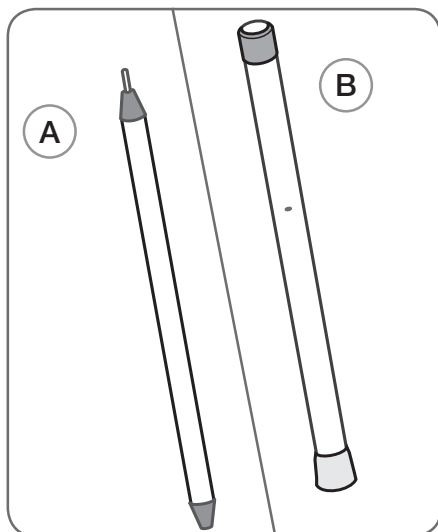

**CARAVANSTORE / XL**

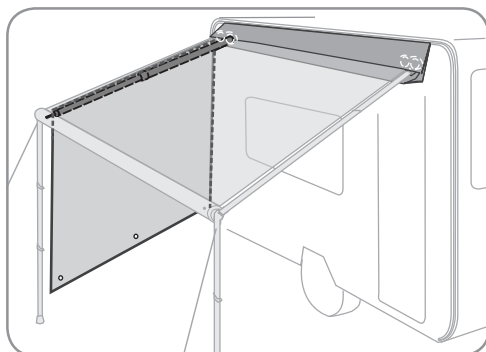

**F35**

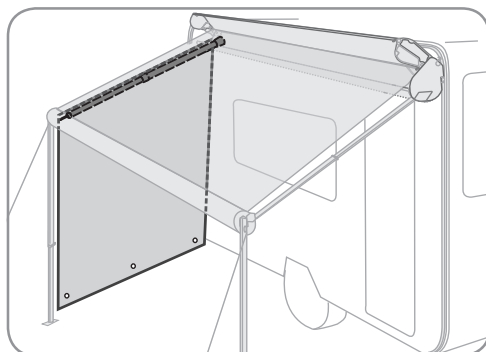

## CARAVANSTORE

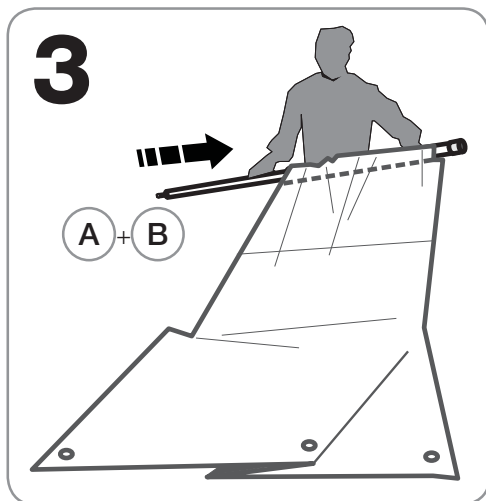
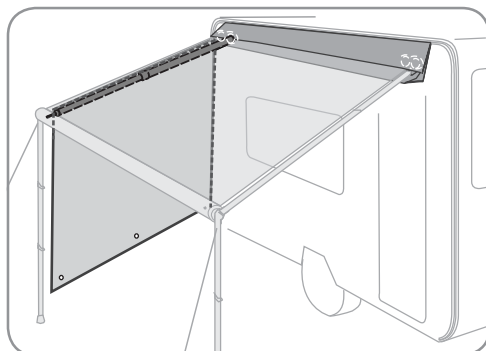
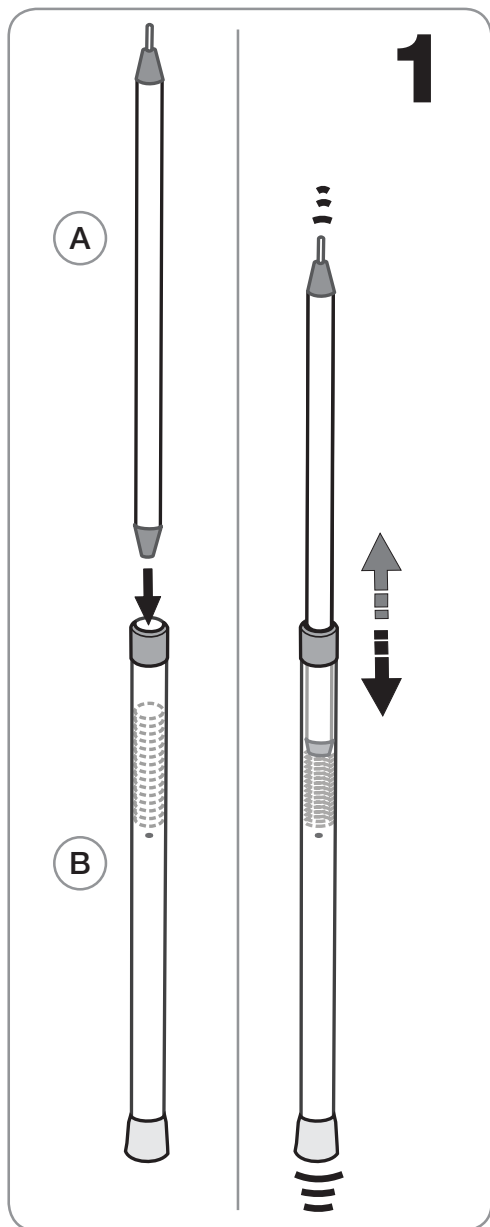

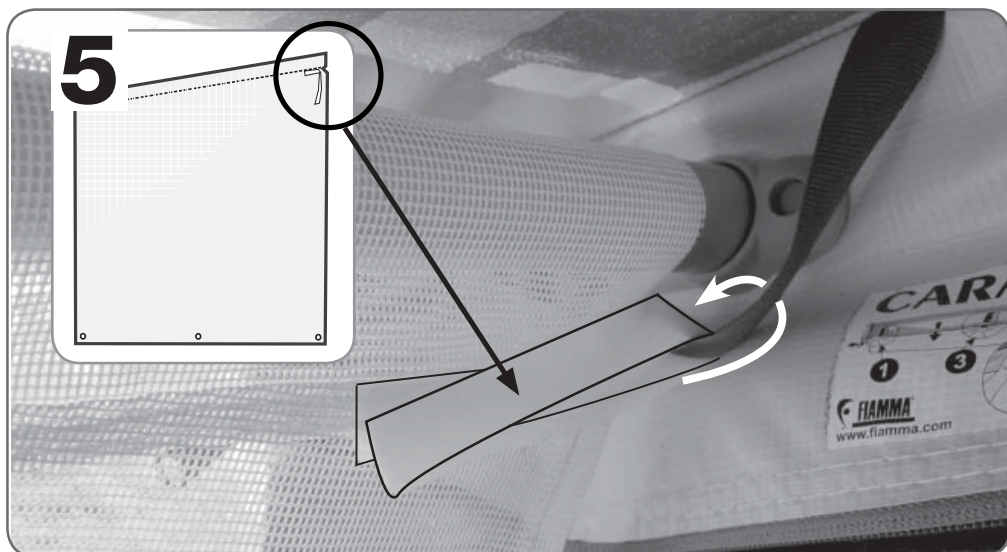
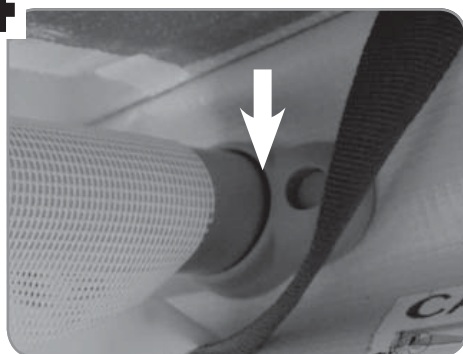
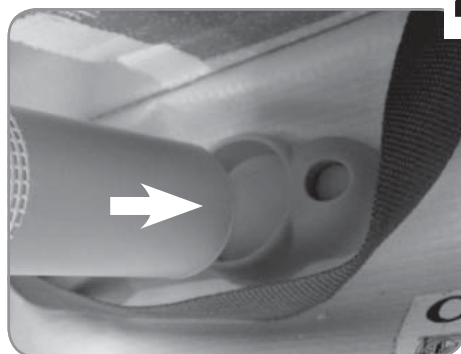
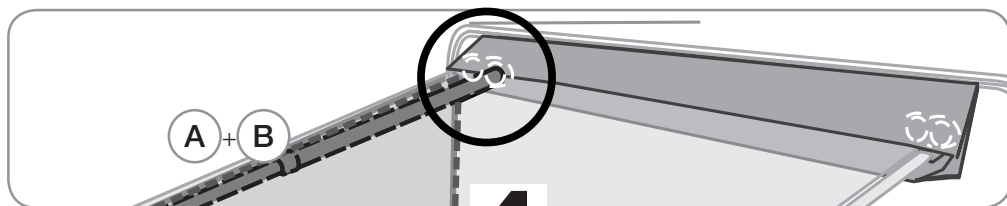

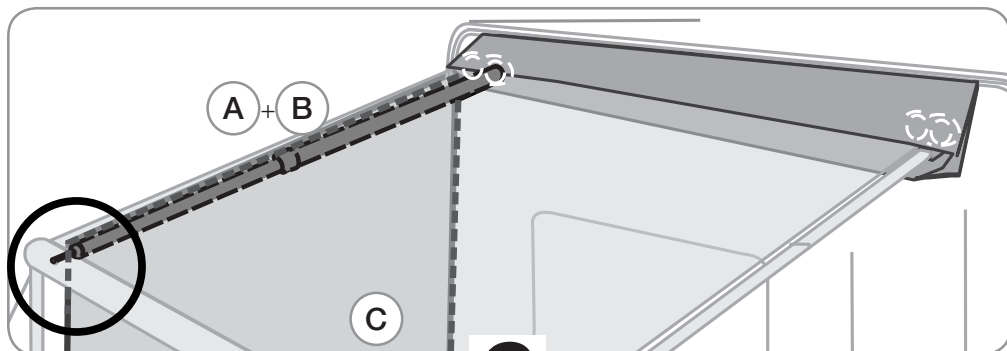

**6**

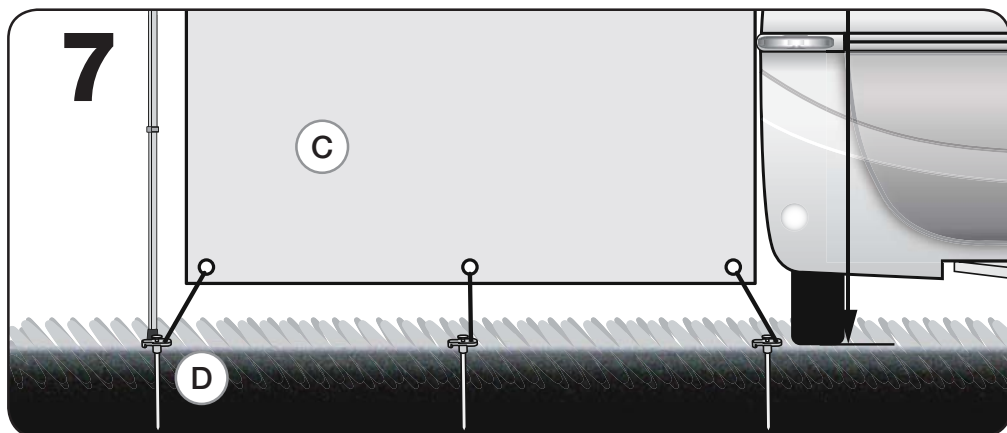
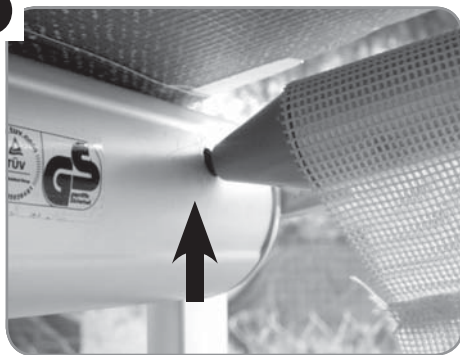
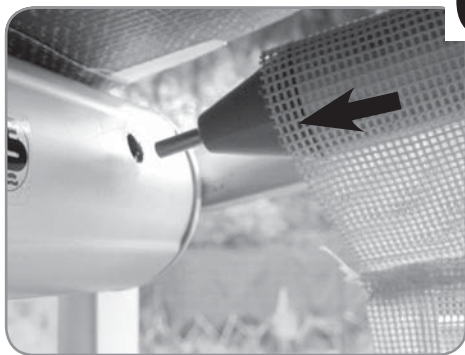

**7**

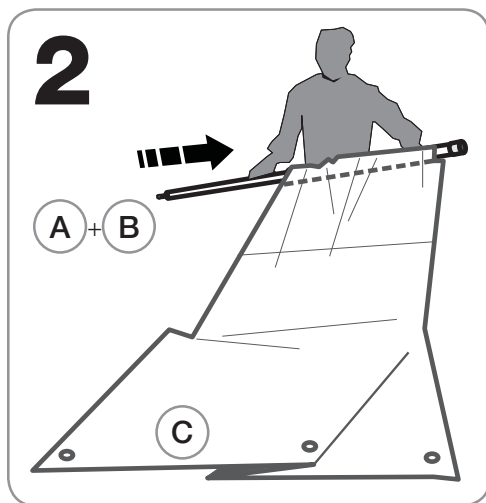
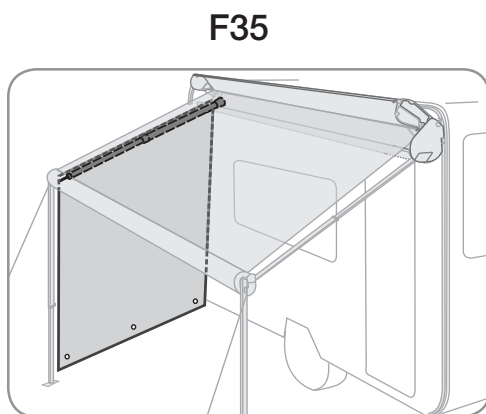
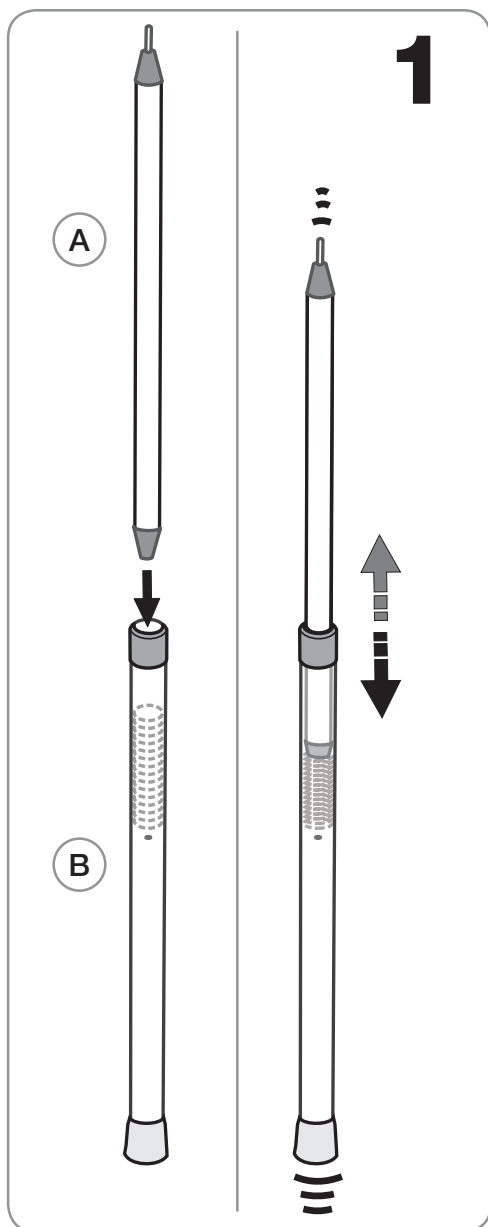

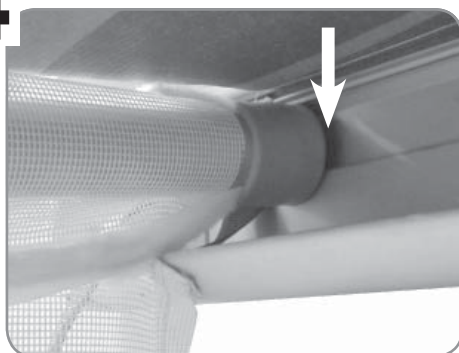
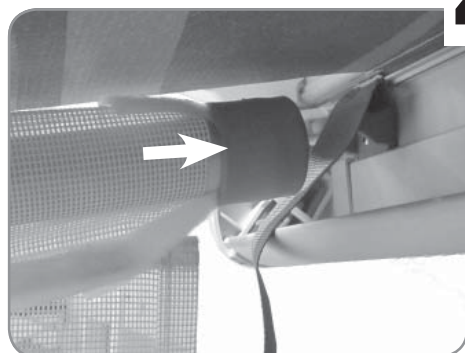
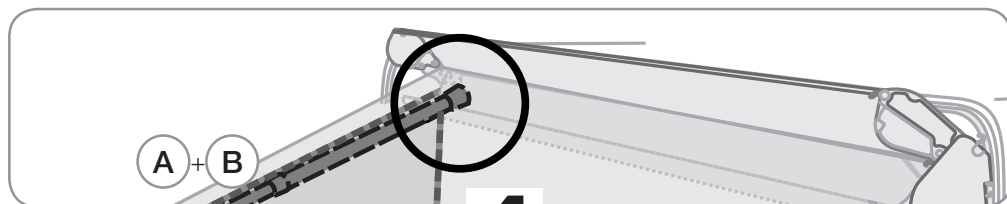
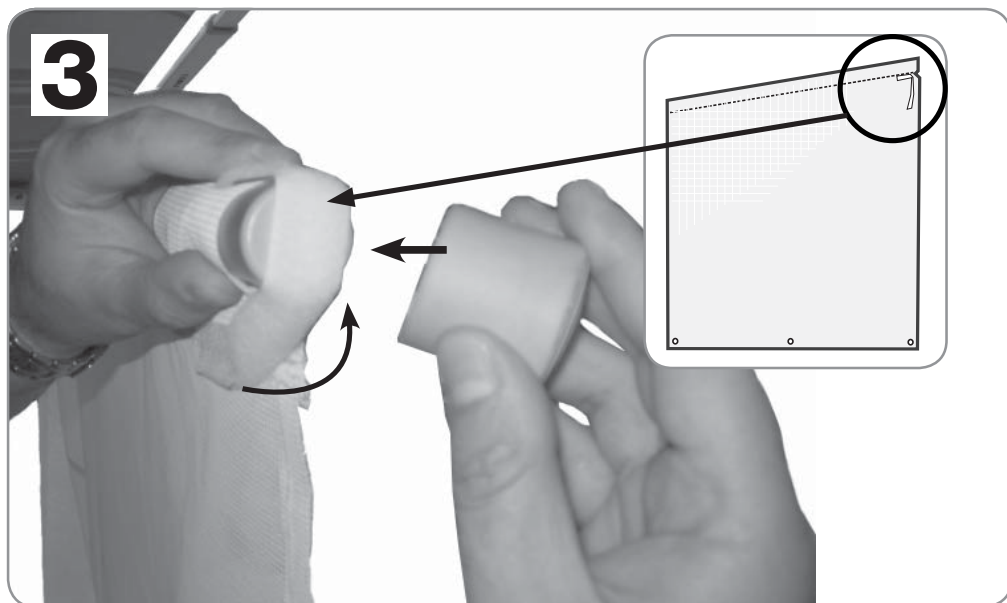



**DE** Montageanleitung  
**FR** Instructions de montage  
**IT** Istruzioni di montaggio

**EN** Installation instructions  
**ES** Instrucciones de montaje

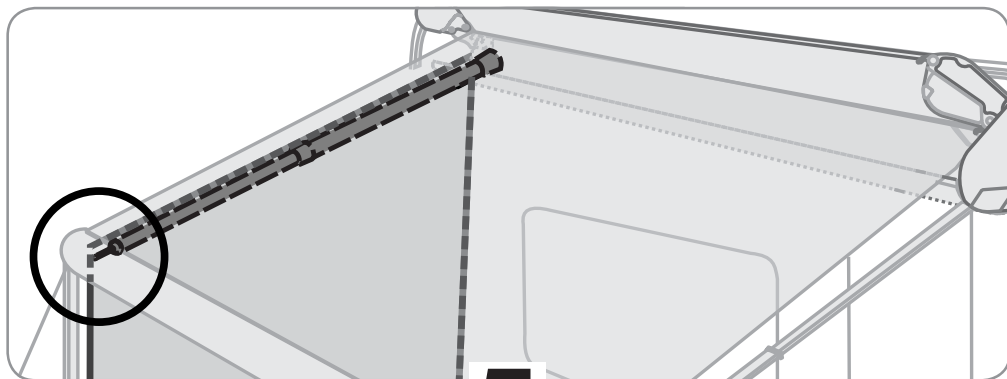

**5**

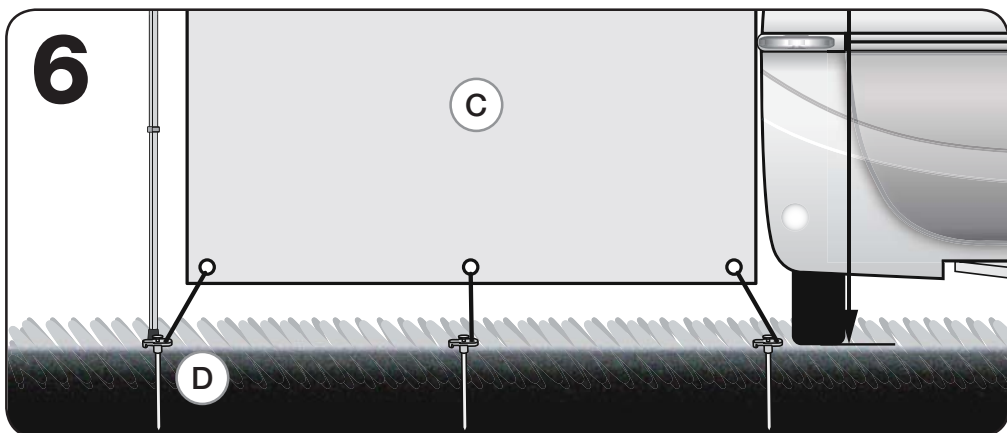
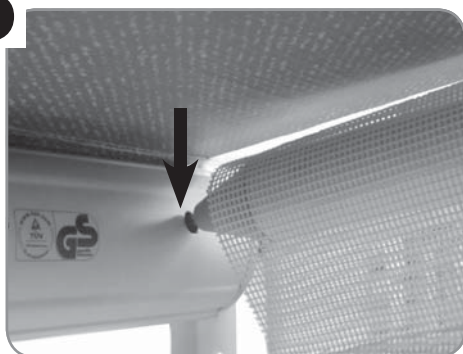
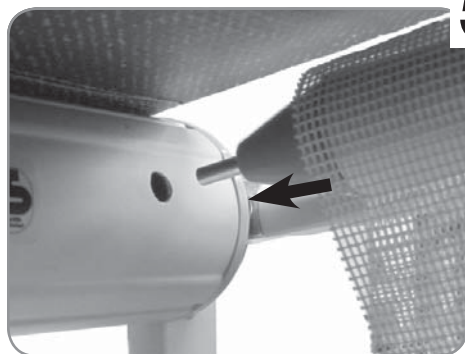

**6**

**C**

**D**

**DE** Garantie Fiamma  
**FR** Garantie Fiamma  
**IT** Garanzia Fiamma

**EN** Warranty Fiamma  
**ES** Garantía Fiamma

**DE**

Im Falle einer Vertragswidrigkeit der Ware, kann der Verbraucher unter den erforderlichen Voraussetzungen gegenüber dem Verkäufer von dem Garantieanspruch zu den festgelegten Bedingungen gemäss den lokalen Rechtsvorschriften Gebrauch machen.

**EN**

In case of defects with regards to materials and manufacturing, the customer is entitled to the warranty in accordance with local laws and regulations of the country in which the product was purchased.

**FR**

En cas d'un défaut de conformité du produit, le consommateur pourra faire valoir ses droits de recours en garantie selon les modalités prévues par les dispositions légales locales, pour autant que les conditions de recours soient remplies.

**ES**

En caso de fallos o defectos de material y de fabricación, el cliente puede hacer valer la garantía de acuerdo con las leyes y reglamentaciones del país en el que el producto haya sido comprado.

**IT**

In caso di difetto di conformità dei beni, il consumatore potrà far valere nei confronti del venditore la garanzia secondo le modalità previste dalle disposizioni di legge locali, ove ne ricorrano i presupposti.





fiamma.com



**Fiamma SpA - Italy**  
Via San Rocco, 56  
21010 Cardano al Campo (VA)

All rights reserved.  
Fiamma S.p.A. reserves the right to  
modify at any time, without notice, prices,  
materials, specifications and models or  
to cease production of any model.

G0\_IS\_98690-859\_revB

**Fiammastore**