



powered by
webOS Hub

ALPHATRONICS QVIEW

With our alphasatronics QVIEW panels, you can enjoy camping entertainment at the highest level. Quantum dot technology (QLED) ensures brilliant colours, strong contrasts and exceptional brightness. Thanks to optimised viewing angle stability, the image remains razor sharp from every perspective – for uncompromising enjoyment, no matter where you are.

THE ELEGANCE OF THE SL LINE

The SL line combines modern design with clever technology: a slim housing made of high-quality materials and a discreet, illuminated shaft below the display add elegant accents. Thanks to its innovative design, there is no annoying IR eye, which rounds off the clear, stylish overall impression – ideal for anyone who values quality and aesthetics.

INTEGRATED DVD PLAYER

The space-saving, elegant slide-in DVD player allows you to play films, series and music directly – without any external devices. Its discreet design blends seamlessly into the housing and combines functionality with mobility. Ideal for flexible use on the go and ready for use at any time.

NEXT GENERATION – WEBOS HUB

Discover the future of television with the latest generation of webOS Hub! Our modern devices offer advanced features such as PVR recording, timeshift, Apple AirPlay and Matter support. Experience a whole new level of entertainment – intuitive, innovative and in first-class alphasatronics quality.

MODEL	SL22DW (QVIEW)		
IMAGE	Screen size	22" / 55 cm	
	Type of display	QLED wide screen display	
	Picture format (widescreen)	16:9 Widescreen	
	Viewing angle	178° (H) / 178° (V)	
	Resolution	1920 x 1080 / Full-HD	
	Contrast ratio	1000:1	
	Brightness value	350 cd/m ²	
	Response time	< 5 ms	
	Image modes	6	
	alphatronics CIS (Color Improvement System)	•	
	SOUND	Music output (RMS)	2 x 5 W
		Integrated speaker	•
		Stereo sound	•
alphatronicsAUDIO+		-	
Sound modes		5	
BLUETOOTH®	Bluetooth® version	5.0	
	Bluetooth® range	30 m	
	Bluetooth® surround	•	
	Playback direction (transmitter & receiver)	•	
RECEPTION	Integrated triple tuner (DVB-S/S2 + DVB-T/T2 + DVB-C)	•	
	Video encoding	MPEG-2 / MPEG-4	
	HEVC standards	H.264 / H.265	
RECEPTION (SAT)	CI+ module slot	• / Version 1.4	
	HbbTV	•	
	Automatic station scan	•	
	Country-specific channel lists	•	
	Fast scan	•	
	LCN (Logical Channel Numbering)	•	
	Electronic Program Guide (EPG)	•	
	Signal quality indication (DVB-S/S2)	•	
	Teletext (TOP system)	•	
	PROGRAM MEMORY	Favorite list	•
max. stations: DVB-T/C		500	
max. stations: DVB-S2		4000	
PVR		PVR function unlocked	•
	Timeshift	•	
	EPG / Timer recording	• / •	
	Integrated hard disk storage	-	
	Supported storage (via SSD or USB stick)	max. 1 TB	
PLAYBACK	Integrated DVD player	•	
	DVD formats (CD, DVD, VCD, MP3, DVD-R, DVD-RW, DivX, JPEG)	•	
	Integrated media player	•	
PORTS	F-connection (SAT)	•	
	IEC connector (antenna)	•	
	HDMI™ socket	2x	
	HDMI™: ARC / CEC support	• / •	
	AV IN / AV OUT	• / -	
	Headphone output (3.5 mm)	•	
	Toslink / SPDIF (Optical)	•	
	RCA IN (Audio/Video)	-	
	Digital Coaxial OUT	-	
	USB socket (2.0 standard) / Output (mA)	2x / 1A (max.)	
	NETWORK	Dual band WiFi (2.4 GHz / 5 GHz)	• / •
External Wifi antenna		•	
RJ45 (LAN)		•	
SMART	SMART platform	webOS Hub 2.0S	
	Netrange	-	
	APP Store	Content Store	

APPLE AIRPLAY & HOMEKIT

With alphatronics, you can harness the full potential of your Apple ecosystem. Thanks to Apple AirPlay 2, you can stream content seamlessly and in the best quality, while Apple HomeKit gives you complete control over your smart home – anytime, anywhere. Enjoy maximum convenience, flexibility and a first-class entertainment experience.

FLEXIBLE VIEWING WITH PVR RECORDING

Never miss a moment again: with the PVR recording function, you can save your favourite programmes and watch them whenever you want. The timeshift function allows you to pause, rewind or fast-forward the programme you are watching. This makes watching TV more convenient and personal than ever before.

25 YEARS OF EXPERIENCE AND INNOVATION

Our many years of experience in consumer electronics form the basis for the continuous development of our TV sets. As a sign of this tradition, our products have been bearing the ‘German Quality – Since 1999’ seal since this year – a seal of quality for exceptional reliability, innovation and the highest quality standards.

CAREFULLY TESTED – MADE FOR ANY EXTREME

Our TV sets not only meet all legal requirements, but also pass rigorous vibration and climate tests. Whether it's freezing temperatures at the North Cape or extreme heat in the desert, alphatronics devices offer reliable performance at all times and guarantee unrestricted functionality under all conditions.

MODEL	SL22DW (QVIEW)	
UPDATE	OTA (Over The Air) update	•
	Manual update via USB	-
POWER SUPPLY	Input voltage	10.5 - 30 V DC
	On/off switch	•
	Power consumption kWh/1000h	15
	Power consumption standby	< 0.5 W
	Energy efficiency class	E
	EPREL registration number	0
FEATURES	Sleep timer	•
	Multilingual OSD menu	•
	Parental control	•
	LG Channels / LG Fitness	• / •
	Smart Home: Matter IoT	•
	Apple AirPlay / HomeKit	• / •
	Corrosion protected electronics	•
PROTECTION	Overvoltage protection	•
	Reverse polarity protection	•
	Repairability Index (France)	 6,1 INDICE DE RÉPARABILITÉ
GENERAL	Dimensions with base (W x H x D)	496 x 321 x 110 mm
	Dimensions without base (W x H x D)	496 x 291 x 45 mm
	Weight (with/without base in kg)	3.55 kg / 3.35 kg
	Housing color	black brushed
	VESA standard	100 x 100 mm
APPROVALS	CE, UKCA, ECE-R10 (E24*10R06/03*5337*02)	
EAN CODE	Product ID	SL22DW (QVIEW)
	Internal item number	991654
	EAN	4260037136820

ACCESSORIES

TV set, remote control, DVD remote control, DVB-T2 aerial (AN5), 12 cigarette lighter cable (ProCar), mounting accessories, operating instructions I Note! The included accessories may vary slightly depending on the region, dealer or equipment variant.

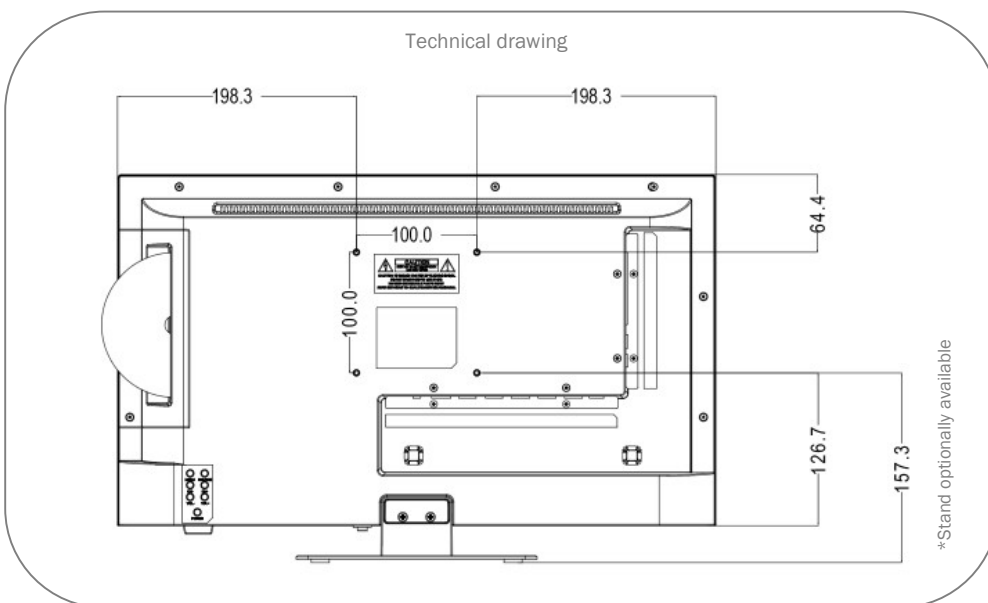
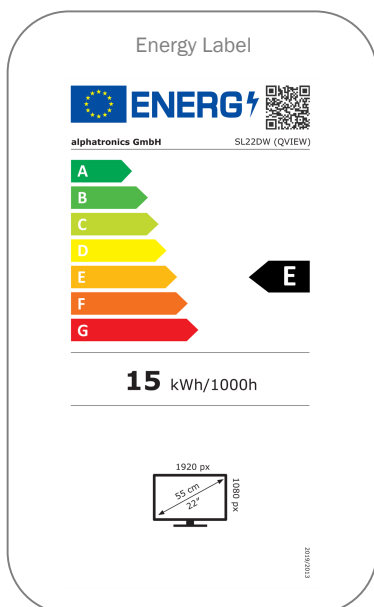

LEGAL INFORMATION

webOS Hub and ThinQ are trademarks of LG Electronics Inc. | Google, YouTube, other marks are trademarks of Google LLC. | Apple, AirPlay, Apple Home and HomeKit are trademarks of Apple Inc. registered in the U.S. and other countries and regions. | The Bluetooth® word mark and logos are registered trademarks owned by Bluetooth SIG, Inc. and any use of such marks by alphatronics is under license. | The terms HDMI, HDMI High-Definition Multimedia Interface, HDMI trade dress and the HDMI Logos are trademarks or registered trademarks of HDMI Licensing Administrator, Inc. | Accessories may vary depending on the region, dealer or trim level. | Streaming services and apps are subject to change or discontinuation without notice. | Streaming service availability varies by region. | Other names or terms mentioned may be the trademarks or registered trademarks of their respective owners.

